

THIS DRAWING IS UNPUBLISHED. RELEASED FOR PUBLICATION  
 © COPYRIGHT BY TYCO ELECTRONICS CORPORATION. ALL INTERNATIONAL RIGHTS RESERVED.

LOC	DIST	REVISIONS					
GP	00	P	LTR	DESCRIPTION	DATE	DWN	APVD
		K		REVISED PER ECO-08-011977	24JUL08	JDP	CWR

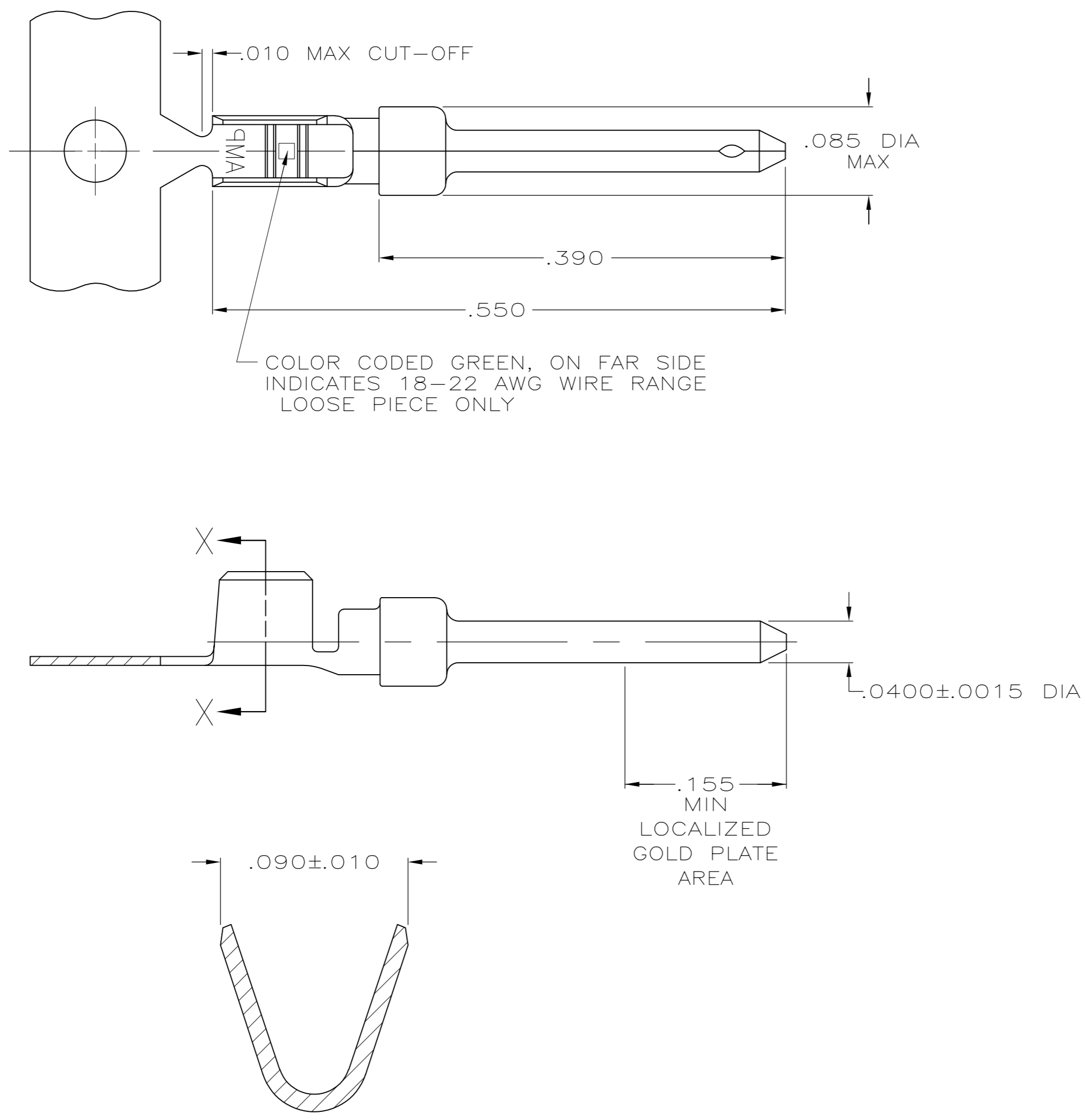

SECTION X-X  
 WIRE BARREL  
 SCALE 20:1

- 1 FOR MINI-APPLICATOR.
- 2 FOR HAND TOOL USE ONLY.
- 3. WIRE RANGE OF 18-22 AWG.
- 4. .068 MAX INSULATION DIAMETER ALLOWABLE WHEN USING 91067-2 EXTRACTION TOOL.
- 5. GOLD PLATING MAY NOT APPEAR ON CARRIER STRIP.
- 6 GOLD PLATING PER MIL-G-45204.  
 NICKEL PLATING PER QQ-N-290.  
 TIN PLATING PER MIL-T-10727.
- 7 GOLD PLATED IN LOCALIZED GOLD PLATE AREA AS FOLLOWS:  
 .000030 MIN GOLD IN MATED AREA,  
 GOLD FLASH ON REMAINDER OF CONTACT, ALL OVER .000050  
 MIN NICKEL UNDERPLATE.  
 OR  
 GOLD FLASH OVER  
 PALLADIUM-NICKEL PLATE, .000030 MIN TOTAL IN MATED AREA,  
 GOLD FLASH ON REMAINDER OF CONTACT, ALL OVER  
 .000050 MIN NICKEL UNDERPLATE.
- 8 PLATED WITH GOLD FLASH OVER  
 .000030 MIN NICKEL.
- 9 PLATED WITH GOLD FLASH IN LOCALIZED GOLD PLATE AREA,  
 TIN PLATED WIRE BARREL, OVER  
 .000030 NICKEL.
- 10 GOLD PLATED IN LOCALIZED GOLD PLATE AREA  
 .000030 GOLD IN MATED AREA,  
 TIN PLATED WIRE BARREL, OVER  
 .000050 NICKEL.
- 11 OBSOLETE.
- 12 SUPERSEDED BY 745229-4

10	11-745229-3	11-745229-1
9	11-745229-0	11-745229-8
8	745229-7	745229-5
7	745229-4	745229-2
FINISH	LOOSE PIECE 2	PART NUMBER 1

THIS DRAWING IS A CONTROLLED DOCUMENT.		DWN S.WELDON 9-9-86	Tyco Electronics Corporation Harrisburg, PA 17105-3608	
DIMENSIONS: INCHES		CHK C.RICHARD 9-9-86	NAME	
TOLERANCES UNLESS OTHERWISE SPECIFIED:		APVD V.KUMAR 9-10-86	PIN CONTACT, SIZE 20 DF, 18-22 AWG, .068 MAX INSULATION DIA	
0 PLC ± -	1 PLC ± -	PRODUCT SPEC	SIZE A2	CAGE CODE 00779
2 PLC ± -	3 PLC ± .005	APPLICATION SPEC	DRAWING NO C=745229	RESTRICTED TO
4 PLC ± -	ANGLES ± -	114-10000	SCALE 10:1	SHEET 1 of 1
MATERIAL BRASS PER MIL-C-50	FINISH SEE TABLE	WEIGHT -	REV K	
		CUSTOMER DRAWING		

745229

A